



BRITISH UNIVERSITIES
& COLLEGES SPORT



BRITISH UNIVERSITIES & COLLEGES SPORT NATIONAL FLEET RACING CHAMPIONSHIPS SATURDAY 7TH AND SUNDAY 8TH NOVEMBER 2015 SAILING INSTRUCTIONS

1. RULES

- 1.1. The regatta will be governed by the rules as defined in *The Racing Rules of Sailing*. The BUCS General Regulations will also apply with respect to eligibility and entry. The British Universities Sailing Associations' Constitution and Standing Orders shall apply.
- 1.2. All competing boats shall comply with the Cardiff Harbour Authority Bye-Laws and any relevant Local Notices to Mariners. A copy will be posted on the Official Notice Board and is available at http://www.cardiffharbour.com/content.asp?nav=12,104&parent_directory_id=1
- 1.3. Competitors shall comply with the Cardiff Bay Yacht Club (CBYC) Code of Conduct. A copy of which will be available to competitors at registration.
- 1.4. The Race Committee may not list the results of any boat which does not display her registered sail number. No boat shall change her sail number after registration without the prior written permission of the Race Committee.
- 1.5. Instructions given by any safety craft in respect of actions relating Harbort Bye-Laws or Club Code of Conduct will be deemed to have come from the Organising Authority. Disregarding these instructions may lead to disqualification and subsequent exclusion from the event.
- 1.6. Racing Rules 35, 40, 60.1, 64.1, 66, A4, A5 will be changed under SI 15, 25.5, 16.5, 14.2, 16.8, 18.6;15, and 15.

2. NOTICES TO COMPETITORS

- 2.1. Notices to competitors will be posted on the Official Notice Board located on the outside of CBYC.
- 2.2. There will be a **competitors briefing at 0930hrs on Saturday** and at **0915hrs on Sunday**. All helms and crews are required to attend.

3. CHANGES TO THE SAILING INSTRUCTIONS

- 3.1. Changes to the Sailing Instructions will be posted at least 60 minutes before the advertised start time of the first race to which it applies, except that any change to the schedule of races for a day will be posted no later than 21.30hrs on the previous day.
- 3.2. The Race Committee will hoist Flag "L" with one sound signal on the mast on the CBYC balcony when an amendment has been posted.

4. SIGNALS MADE ASHORE

- 4.1. Signals made ashore will be displayed on the mast on the CBYC balcony.
- 4.2. When "Flag AP" is displayed ashore racing will commence not less than 30 minutes after AP is lowered. This changes RRS Race Signals AP.

5. SCHEDULE OF RACES

5.1. Day	Race	Warning Signal
Saturday 7th	1	10:55hrs
	2	As soon as possible after Race 1
	3	As soon as possible after Race 2
Sunday 8th	4	10:25hrs
	5	As soon as possible after Race 4
	6	As soon as possible after Race 5

5.2. More than 3 races may be sailed on either day at the discretion of the Race Committee. However, no more than 4 races will be sailed on a single day.

5.3. On the last day of the regatta, no warning signal will be made after 15.00hrs, except as a result of a general recall.

5.4. Classes will race in accordance with the signals of the Race Committee afloat. However is the intention of the Race Committee to start the classes in the following order:

Race Course 1	Firefly Class
Race Course 2	Laser Handicap Class followed by Fast Handicap Class followed by Slow Handicap Class

6. CLASS FLAGS

The Class Flags will be:

CLASS	FLAG
Laser Handicap Class	Numeral Pennant ONE (White with red disc)
Fast Handicap Class	Numeral Pennant TWO (Blue with white disc)
Slow Handicap Class	Numeral Pennant THREE (Red/White/Blue)
Firefly Class	Numeral Pennant FOUR (Red with white cross)

7. RACING AREA

The racing area will be Cardiff Bay, with the exact location of race course 1 and 2 confirmed at the briefing each morning.

8. COURSES

8.1. The diagrams in Addendum show the courses, the order in which marks are to be passed, and the side on which each mark is to be left.

8.2. The course configuration will be displayed on the rear of the Committee boat. (E.g. O2 meaning Outer Loop 2 laps)

9. MARKS

9.1. The course marks will for both courses will be inflatable marks. The marks for each course and their colours will be described on the Official Notice Board prior to the start of the first race.

9.2. Unless otherwise stated, all marks are rounding marks.

10. AREAS THAT ARE OBSTRUCTIONS

10.1. The prohibited areas and obstructions that boats shall not sail within at any time will be announced at the competitors briefing on the first day of the regatta.

11. THE START

11.1. The starting line will be between the mast of the Committee Boat flying an orange flag and the ODM (Outer Distance Mark). The ODM will be a Dan buoy with an orange flag.

- 11.2. A boat starting later than 4 minutes after her starting signal will be scored Did Not Start (DNS) without a hearing. This changes rule A4.
- 11.3. Boats whose warning signal has not been made shall avoid the starting area during the starting sequence for other races.

12. CHANGE OF COURSE

To change the next leg of the course, the race committee will move the original mark, or the finishing line, to a new position.

13. THE FINISH

- 13.1. The finish line will be between the mast of the Committee Boat flying a Blue flag and a Dan buoy flying a Blue flag.
- 13.2. A boat that has finished shall not re-cross the finish line. If she does so, she shall be disqualified from that race.

14. PENALTY SYSTEM

- 14.1. RRS Appendix P will apply. RRS P2.3 is changed so that a third or subsequent penalty shall be retirement only from the race in question (or a non-excludable disqualification without a hearing for that race if the boat fails to retire).
- 14.2. Penalties for a breach of a rule, other than a rule of RRS Part 2, shall be at the discretion of the Protest Committee and may be less than disqualification. This changes RRS 64.1

15. TIME LIMIT

In one design classes, boats failing to finish within 20 minutes after the first boat in her class sails the course and finishes will be scored Did Not Finish (DNF) without a hearing. In handicap classes, boats failing to finish within 30 minutes after the first boat in her class sails the course and finishes will be scored Did Not Finish (DNF) without a hearing. This changes RRS 35, A4 and A5.

16. PROTESTS

- 16.1. The Exoneration Penalty, RYA Advisory Hearing and RYA Arbitration procedures of the RYA Rules Disputes Procedures will be available. Decisions from the RYA Arbitration can be referred to a protest committee but cannot be reopened or appealed. Further details will be published on the Official Notice Board. The Exoneration penalty shall be a 30% place penalty.
- 16.2. Protest forms are available from the Race Office, and completed forms shall be delivered to the Race Office within the protest time limit.
- 16.3. The protest time limit for each race course is 30 minutes after the last boat from their start is ashore.
- 16.4. Notice of protests by the Race Committee or Protest Committee will be posted on the Official Notice Board to inform boats in accordance with RRS 61.1(b).
- 16.5. Breaches of SI 1.2, 1.3, 1.4, 11.4, 13.2, 21.1, and 21.2 shall not be grounds for protest by a boat. This amends RRS 60.1(a).
- 16.6. The schedule of hearings will be posted no later than 30 minutes after the protest time limit expires. Protests will be heard in approximate order of receipt.
- 16.7. The Protest Committee will post a notice of boats penalised under RRS Appendix P.
- 16.8. On Sunday 8 November, the last day of the regatta, a request for reopening a hearing shall be delivered:
 - (a) within the protest time limit if the requesting party was informed of the decision on the previous day; or
 - (b) no later than 30 minutes after the requesting party was informed of the decision on that day. This changes RRS 66.

17. SCORING SYSTEM

- 17.1. The Low Point Scoring system in RRS Appendix A will apply.
- 17.2. Six races are scheduled. If four or more races are sailed, there will be one discard. If three or less races are sailed, all races will be counted.
- 17.3. Two races for each class are required to be completed to constitute a series.

18. SAFETY REGULATIONS

- 18.1. Adequate personal buoyancy must be worn whilst on the pontoons and when afloat. A drysuit or wetsuit does not constitute adequate personal buoyancy. This changes RRS 40.
- 18.2. A drysuit or wetsuit must be worn whilst afloat.
- 18.3. All boats are required to carry a 3 metre (Minimum 8mm) rope attached to their bow.
- 18.4. Competitors are required to inform the Committee Boat or a safety boat and the Race Office if they retire.
- 18.5. A full tally system for each crew member is mandatory. A 'tally number' will be given to competitors on registration. The tally board will be located adjacent to the slipway within the CBYC compound. Both helm and crew are required to tally out and wear their wristband whilst on the water. They shall be returned to their correct hook on returning ashore.
- 18.6. Competitors failing to tally out or tally in may be scored Did Not Start (DNS); without a hearing. This changes RRS A4.

19. REPLACEMENT OF CREW OR EQUIPMENT

- 19.1. The substitution of competitors is not permitted without the prior written approval of the Organising Authority. Competitors are referred to the Notice of Race which contains the conditions for crew substitution.
- 19.2. The substitution of equipment (replacement, lost or damaged) will not be permitted without the prior written approval of the Protest Committee. Requests shall be made at the first reasonable opportunity.

20. EQUIPMENT AND MEASUREMENT CHECKS

A boat or equipment may be inspected at any time for compliance with the class rules and sailing instructions. On the water, a boat can be instructed by a race committee equipment inspector or measurer to proceed immediately to a designated area for inspection.

21. IDENTIFICATION AND ADVERTISING WHILE RACING

- 21.1. Each day while racing, the first, second and third boats in series ranking at the beginning of the day shall display a yellow, blue and red sail sticker respectively. The organising authority will supply the stickers.
- 21.2. Stickers provided by the OA as per SI. 20.1, should be applied to sails with the sail dry and clean (from salt etc). Stickers should be applied such that they are clearly visible to others on the water and as near to the lowest part of the leech as practically possible. See Addendum B.

22. SUPPORT BOATS

Team Leaders, coaches and other support personnel shall stay outside the areas where boats are racing from the time of the preparatory signal for the first fleet to start until all boats have finished or retired or the race committee signals a postponement, general recall or abandonment.

23. RADIO COMMUNICATION

Except in an emergency, a boat shall neither make radio transmissions while racing nor receive radio communications not available to all boats. This restriction also applies to mobile telephones.

24. PRIZES

Prizes will be awarded as follows:

Men's Team Prize: The Men's team prize will be awarded to teams from the same institution which has the 3 boats of all males having the combined lowest score. Each boat must have raced in a class which has 15 or more entries. If a class has less than 15 entries and is combined with another class, a boat which would have raced in the former class will not count. BUCS points are awarded to the top 8 teams.

Ladies Team Prize: The Ladies team prize will be awarded to teams from the same institution which has the 3 boats of all females who have the combined lowest score. Each boat must have raced in a class which has 15 or more entries. If a class has less than 15 entries and is combined with another class, a boat which would have raced in the former class will not count. BUCS points are awarded to the top 8 teams.

BUCS Medals and points will be awarded to boats placed 1st, 2nd and 3rd in the Firefly, Laser handicap, Fast Handicap and Slow handicap fleets. Boats placed 4th in the Firefly, Laser handicap, Fast Handicap and Slow handicap fleets will also be awarded BUCS points.

25. DISCLAIMER OF LIABILITY & INSURANCE

- 25.1. A boat is entirely responsible for her own safety, whether afloat or ashore, and nothing else reduces this responsibility. Competitors are reminded of RRS 4, Decision to Race.
- 25.2. It is for the boat to decide whether she is fit to sail in the conditions in which she will find herself. By launching or going afloat, the boat confirms that she is fit for those conditions and her crew is competent to sail and compete in them.
- 25.3. Nothing done by the organisers (BUCS, BUSA, CBYC, or Cardiff University) can reduce the responsibility of the boat nor will it make the organisers responsible for any loss, damage, death or personal injury, however it may have occurred, as a result of the boat taking part in the racing. The organisers encompass everyone helping to run the race and the event, and include the Organising Authority, the Race Committee, the Protest Committee, patrol boats and beach masters.
- 25.4. The provision of patrol boats does not relieve the boat of her responsibilities.
- 25.5. All competitors shall comply with SI 18.1.
- 25.6. Boats may be inspected by the Race Committee to ensure they are in a condition fit to go afloat. If found to be unsafe, the Race Committee may direct that the boat shall not go afloat until the faults are rectified.
- 25.7. Each competitor shall be responsible for ensuring that he / she and the boat to be sailed have adequate third party insurance cover to a minimum of £3,000,000.

Addendum A: Courses

COURSE ONE – OUTER LOOP (Course sign O)

- ONE LAP** Start – 1, 2, 3, 4, Finish
- TWO LAPS** Start – 1, 2, 3, 2, 3, 4, Finish
- THREE LAPS** Start – 1, 2, 3, 2, 3, 2, 3, 4, Finish

Mark 4 shall be left to Port on the final leg to the Finish

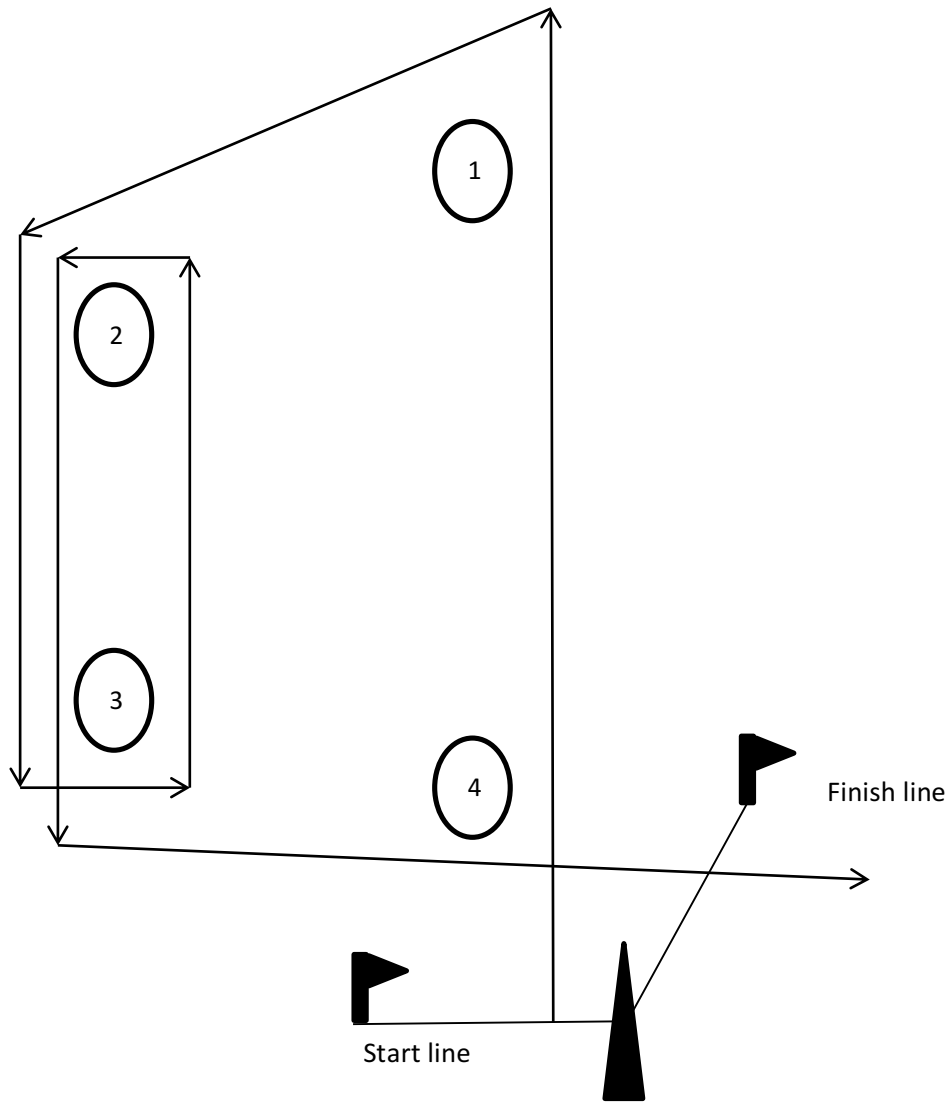

COURSE TWO – INNER LOOP (Course sign I)

- ONE LAPS** Start – 1, 2, 3, 4, Finish
- TWO LAPS** Start – 1, 4, 1, 2, 3, 4, Finish
- THREE LAPS** Start – 1, 4, 1, 4, 1, 2, 3, 4, Finish

Mark 4 shall be left to Port on the final leg to the Finish

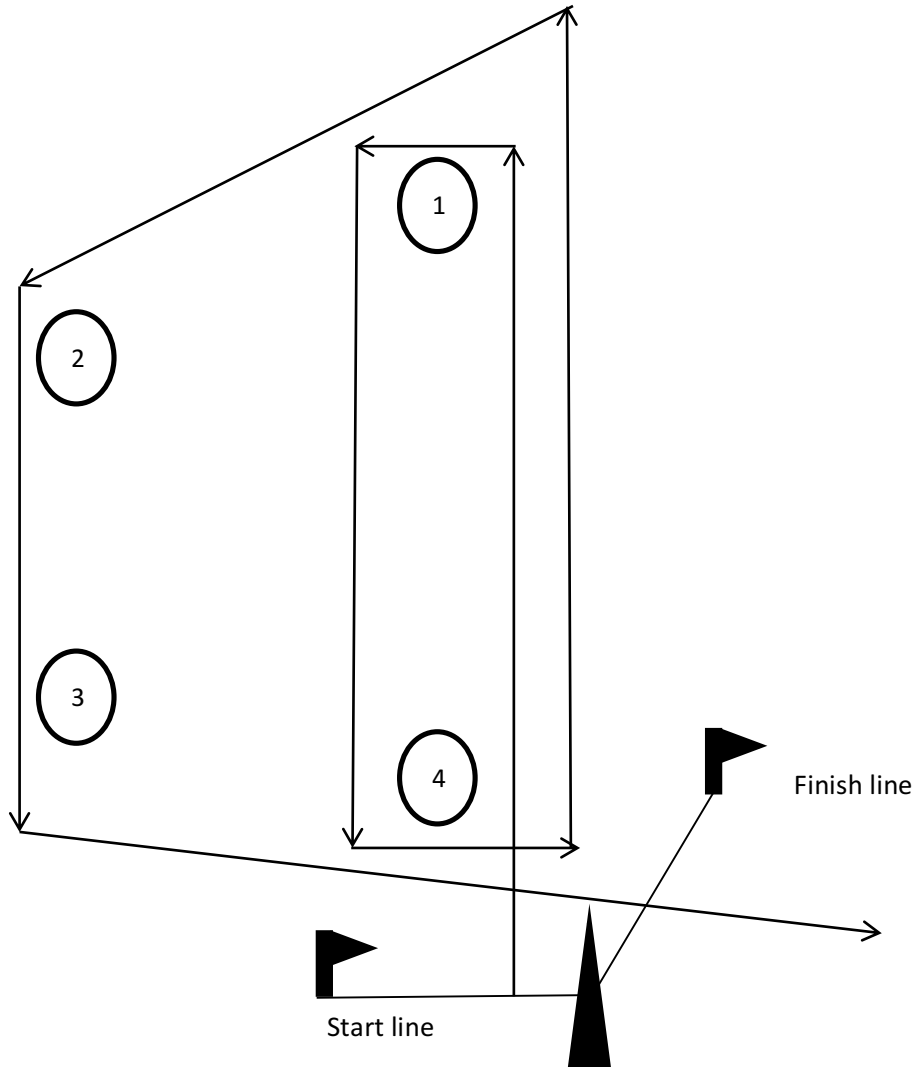

COURSE THREE – WINDWARD – LEEWARD (Course sign L)

- ONE LAPS** Start – 1, 2, Finish
- TWO LAPS** Start – 1, 2, 1, 2, Finish
- THREE LAPS** Start – 1, 2, 1, 2, 1, 2, Finish

Mark 2 shall be left to Port on the final leg to the Finish

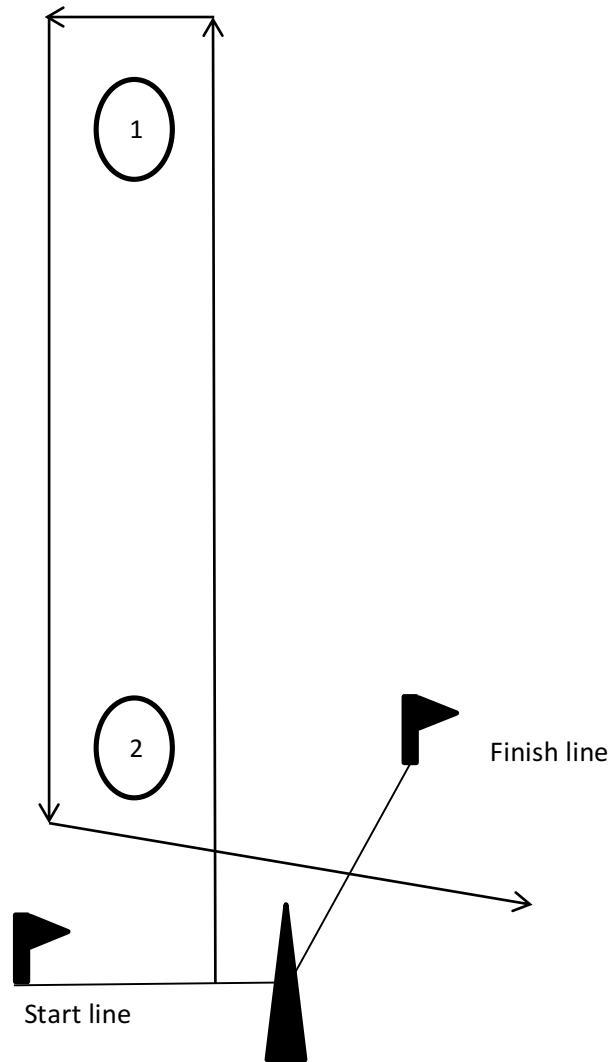

Addendum B: Sail Stickers for overnight 1st, 2nd, 3rd.

