



BRITISH UNIVERSITIES
& COLLEGES SPORT



mountbatten
watersports & activities centre

BRITISH UNIVERSITIES & COLLEGE SPORT NATIONAL FLEET RACING CHAMPIONSHIPS

SATURDAY 1st AND SUNDAY 2nd NOVEMBER 2014

SAILING INSTRUCTIONS

1. RULES

- 1.1. The regatta will be governed by the rules as defined by the Racing Rules of Sailing 2013 -2016. The BUCS General Regulations will also apply with respect to eligibility and entry. The British Universities Sailing Associations' Constitution and Standing Orders shall apply.
- 1.2. Dockyard Port of Plymouth Order and the Plymouth Local Notices to Mariners shall apply to all competitors. All competing boats shall comply with such regulations as may be in force within the Dockyard Port of Plymouth. A copy of these will be posted on the Official Notice Board and is available at <http://www.qhmplymouth.org.uk/regulations/dppo>
- 1.3. Competitors need to adhere to the Mount Batten Water Sports and Activity Centre code of conduct. <http://www.busa.co.uk/wp-content/uploads/downloads/2013/09/Code-of-Conduct-MBCv1-2013.pdf> Instructions given by any safety craft in respect of actions relating to the Port Order will be deemed to have come from the organising authority. Disregarding these instructions may lead to disqualification and subsequent exclusion from the event.
- 1.4. The Race Committee will not list the results of any boat which does not display her registered sail number. No boat shall change her sail number after registration without the prior written permission of the Race Committee.
- 1.5. Bow numbers for Fireflies will be provided by the Organising Authority and shall be displayed in accordance with SI Addendum B. These bow numbers will be used as the identifying mark on the Firefly. This changes rule 30.3 and 77.

2. NOTICES TO COMPETITORS

- 2.1. Notices to competitors will be posted on the Official Notice Board located in the Waterfront room.
- 2.2. There will be a **competitors briefing at 0945 hrs on Saturday** and at **0915 on Sunday** outside the reception area/patio (depending upon the weather).
- 2.3. The Race Office (Ocean room - upstairs) will be open from 0800 on both days and on Friday from 1600-1800.

3. CHANGES TO THE SAILING INSTRUCTIONS

- 3.1. Changes to the Sailing Instructions will be posted at least 60 minutes before the advertised start time of the first race to which it applies except that any change to the schedule of races for a day will be posted no later than 21.30hrs on the previous day.
- 3.2. The Race Committee will hoist Flag "L" with one sound signal on the Centre Flag Mast when an amendment has been posted.

4. SIGNALS MADE ASHORE

- 4.1. Signals made ashore will be displayed on the Centre Flag Mast.

4.2. When "Flag AP" is displayed ashore racing will commence not less than 30 minutes after AP is lowered. This changes RRS Race Signals AP.

5. SCHEDULE OF RACES

5.1. Day	Race	Warning Signal
Saturday	1	1055hrs
	2	As soon as possible after previous race
	3	As soon as possible after previous race
	4	As soon as possible after previous race
Sunday	5	1025hrs
	6	As soon as possible after previous race

5.2. On Sunday 2 November, no warning signal, except as a result of a general recall, will be scheduled after 15.00hrs.

5.3. A class which has a General Recall will re-start their race before any other scheduled starts for that race.

5.4. Classes will race in accordance with the signals of the Race Committee afloat. However is the intention of the Race Committee to race the classes in the following order:

Race Zone Blue	Laser Handicap Class followed by Fast Handicap Class followed by Slow Handicap Class
Race Zone Red	Firefly Class

More than 3 races may be sailed on either day at the discretion of the Race Committee.

6. CLASS FLAGS

6.1. The Class Flags will be:

CLASS	FLAG
Laser Handicap Class	Numeral Pennant ONE (White with red disc)
Fast Handicap Class	Numeral Pennant TWO (Blue with white disc)
Slow Handicap Class	Numeral Pennant THREE (Red/White/Blue)
Firefly Class	Numeral Pennant FOUR (Red with white cross)

7. RACING AREA

7.1. The racing area will be Plymouth Sound, north of the breakwater and will be confirmed at the briefing each morning.

7.2. The Committee Boat for Race Zone Red will be Ellena (a white Bavaria Sloop).

7.3. The Committee Boat for Race Zone Blue will be Dippy Maid (a white 30' Motor cruiser).

8. COURSES

8.1. The course configuration will be displayed on the Committee boat. (E.g. O2 meaning Outer Loop 2 laps)

8.2. Course diagrams are in Addendum A.

9. MARKS

9.1. The course marks will be Red (Red Zone- Firefly Class) or Blue (Blue Zone- Laser/ Fast/Slow Handicap Classes) inflatable marks.

10. AREAS THAT ARE OBSTRUCTIONS

10.1. The prohibited areas and obstructions that boats shall not sail within at any time will be announced at the Briefing on Saturday.

11. THE START

11.1. The races will be started in accordance with RRS 26 with the warning signal made 5 minutes before the starting signal.

11.2. The starting line will be between a mast on the Committee Boat flying an orange flag and the ODM (Outer Distance Mark). The ODM will be a Dan buoy with an orange flag.

- 11.3. A boat starting later than 4 minutes after her starting signal will be scored Did Not Start without a hearing. This changes rule A4.
 - 11.4. Boats whose warning signal has not been made shall avoid the starting area during the starting sequence for other races.
12. CHANGE OF COURSE
- 12.1. To change the next leg of the course, the race committee will move the original mark, or the finishing line, to a new position.
13. THE FINISH
- 13.1. The finish line will be between the mast of the Finishing Committee Boat flying a Blue flag and a buoy flying a Blue flag.
 - 13.2. After finishing, competitors shall not re-cross the finish line.
14. TIME LIMIT
- 14.1. The target time for all races is 40 minutes.
 - 14.2. The time limit for all classes will be 55 minutes.
 - 14.3. In one design class boats failing to finish within 20 minutes after the first boat in her class sails the course and finishes; and in handicap classes boats failing to finish within 30 minutes after the first boat in her class sails the course and finishes; will be scored Did Not Finish without a hearing. This changes RRS 35, A4 and A5.
15. PENALTY SYSTEM
- 15.1. RRS Appendix P will apply. RRS P2.3 is changed so that a third or subsequent penalty shall be retirement only from the race in question (or a non-excludable disqualification without a hearing for that race if the boat fails to retire).
 - 15.2. Penalties for a breach of a rule, other than a rule of RRS Part 2, shall be at the discretion of the Protest Committee and may be less than disqualification. This changes RRS 64.1
16. PROTESTS
- 16.1. Protest forms are available from the Race Office and shall be delivered there within the protest time limit.
 - 16.2. The protest time limit is 30 minutes after the last boat is ashore.
 - 16.3. Notice of protests by the Race Committee or Protest Committee will be posted on the Official Notice Board to inform boats under RRS 61.1(b).
 - 16.4. Breaches of SI 1.3, 1.4, 11.4, 13.2 or 17 shall not be grounds for protest by a boat. This amends RRS 60.1(a).
 - 16.5. The schedule of hearings will be posted no later than 30 minutes after the protest time limit expires. Protests will be heard in approximate order of receipt.
 - 16.6. The Protest Committee will post a notice of boats penalised under RRS Appendix P.
 - 16.7. On Sunday 2 November a request for reopening a hearing shall be delivered:
 - (a) within the protest time limit if the requesting party was informed of the decision on the previous day; or
 - (b) no later than 30 minutes after the requesting party was informed of the decision on that day.This changes RRS 66.
17. SCORING SYSTEM
- 17.1. The Low Point Scoring system in RRS Appendix A will apply.
 - 17.2. Six races are scheduled. If four or more races are sailed, there will be one discard. If three or less races are sailed, all races will be counted.
 - 17.3. Two races for each class are required to be completed to constitute a series.
18. SAFETY REGULATIONS
- 18.1. Adequate personal buoyancy must be worn whilst on the pontoons and when afloat. A drysuit or wetsuit does not constitute adequate personal buoyancy.
 - 18.2. A drysuit or wetsuit must be worn whilst afloat.

- 18.3. All boats are required to carry a 3 metre (Minimum 8mm) rope attached to their bow.
- 18.4. Competitors are required to inform the Committee Boat or a safety boat and the Race Office if they retire, particularly if they do not intend to return afloat for a later race that day.
- 18.5. A full tally system for each boat is mandatory. A 'tally number' will be given to competitors on registration. The tally board is located outside the reception area. Both helm and crew are required to tally out and wear their wristband whilst on the water. They shall be returned to their correct hook on returning ashore.
- 18.6. Competitors failing to tally out or tally in will be scored Did Not Start; did not come to starting area without a hearing. This changes RRS A4.
- 18.7. Competitors may take their tally before they are released from the slipway in order to save time.

19. REPLACEMENT OF CREW OR EQUIPMENT

- 19.1. The substitution of competitors is not permitted without the prior written approval of the Organising Authority. Competitors are referred to the Notice of Race which contains the conditions for crew substitution.
- 19.2. The substitution of equipment (replacement, lost or damaged) will not be permitted without the prior written approval of the Protest Committee. Requests shall be made at the first reasonable opportunity.

20. IDENTIFICATION AND ADVERTISING WHILE RACING

- 20.1 Each day while racing, the first, second and third boats in series ranking at the beginning of the day shall display a yellow, blue and red sail sticker respectively. The organising authority will supply the stickers.
- 20.2 Stickers provided by the OA as per SI. 20.1, should be applied to sails with the sail dry and clean (from salt etc). Stickers should be applied such that they are clearly visible to others on the water and as near to the lowest part of the leech as practically possible. See Addendum C.

21. SUPPORT BOATS

- 21.1 Team Leaders, coaches and other support personnel shall stay outside the areas where boats are racing from the time of the preparatory signal for the first fleet to start until all boats have finished or retired or the race committee signals a postponement, general recall or abandonment.
- 21.2 BUSA named coaches/instructors on the Official Notice Board will be providing coaching/instruction support with post race debrief and on the water advice. This changes RRS41 – outside help.

22. TROPHIES & MEDALS

- 22.1. Team prizes will be awarded to the institutions which have the 3 boats that have the combined lowest score for a mens only team and/or a women's only team.
- 22.2. Each boat must have raced in a class which had 10 or more entries. If a class has less than 10 entries and is combined with another class, a boat which would have raced in the former class will not count. BUCS points will be awarded to the top 8 teams (men's and women's).
- 22.3. BUCS Medals will be awarded for the 1st, 2nd and 3rd places boats in the Firefly, Laser, Fast and Slow Handicap fleets raced.
- 22.4. BUCS Points will be awarded to the boats finishing in 1st, 2nd, 3rd and 4th in the Firefly, Laser, Fast and Slow Handicap fleets. The points will be 12, 8, 6 and 4 respectively.
- 22.5. The winners of Race 2 in the Firefly Fleet will be awarded The Marine Institute 150 Years – with Plymouth University Trophy. This trophy will be awarded on Saturday afternoon, as soon as possible after racing.

23. DISCLAIMER & INSURANCE

- 23.1. A boat is entirely responsible for her own safety, whether afloat or ashore, and nothing else reduces this responsibility. Competitors are reminded of RRS 4, Decision to Race.
- 23.2. It is for the boat to decide whether she is fit to sail in the conditions in which she will find herself. By launching or going afloat, the boat confirms that she is fit for those conditions and her crew is competent to sail and compete in them.
- 23.3. Nothing done by the organisers (BUCS, BUSA, Mount Batten Centre or Plymouth University) can

reduce the responsibility of the boat nor will it make the organisers responsible for any loss, damage, death or personal injury, however it may have occurred, as a result of the boat taking part in the racing. The organisers encompass everyone helping to run the race and the event, and include the Organising Authority, the Race Committee, the Protest Committee, patrol boats and beach masters.

- 23.4. The provision of patrol boats does not relieve the boat of her responsibilities.
- 23.5. All competitors shall wear a personal flotation device at all times when afloat. Neither a wet suit nor a dry suit alone constitutes adequate personal buoyancy. This changes RRS 40.1.
- 23.6. Boats may be inspected to ensure that they are in a seaworthy condition by the Race Committee. If found to be unsafe, the Race Committee may direct that the boat shall not go afloat until the faults are rectified.
- 23.7. Each competitor shall be responsible for ensuring that he / she and the boat to be sailed have adequate third party insurance cover to a minimum of £3,000,000.

Addendum A: Courses

COURSE ONE – OUTER LOOP (Course sign O)

ONE LAP Start – 1, 2, 3, 4, Finish

TWO LAPS Start – 1, 2, 3, 2, 3, 4, Finish

THREE LAPS Start – 1, 2, 3, 2, 3, 2, 3, 4, Finish

Mark 4 shall be left to Port on the final leg to the Finish

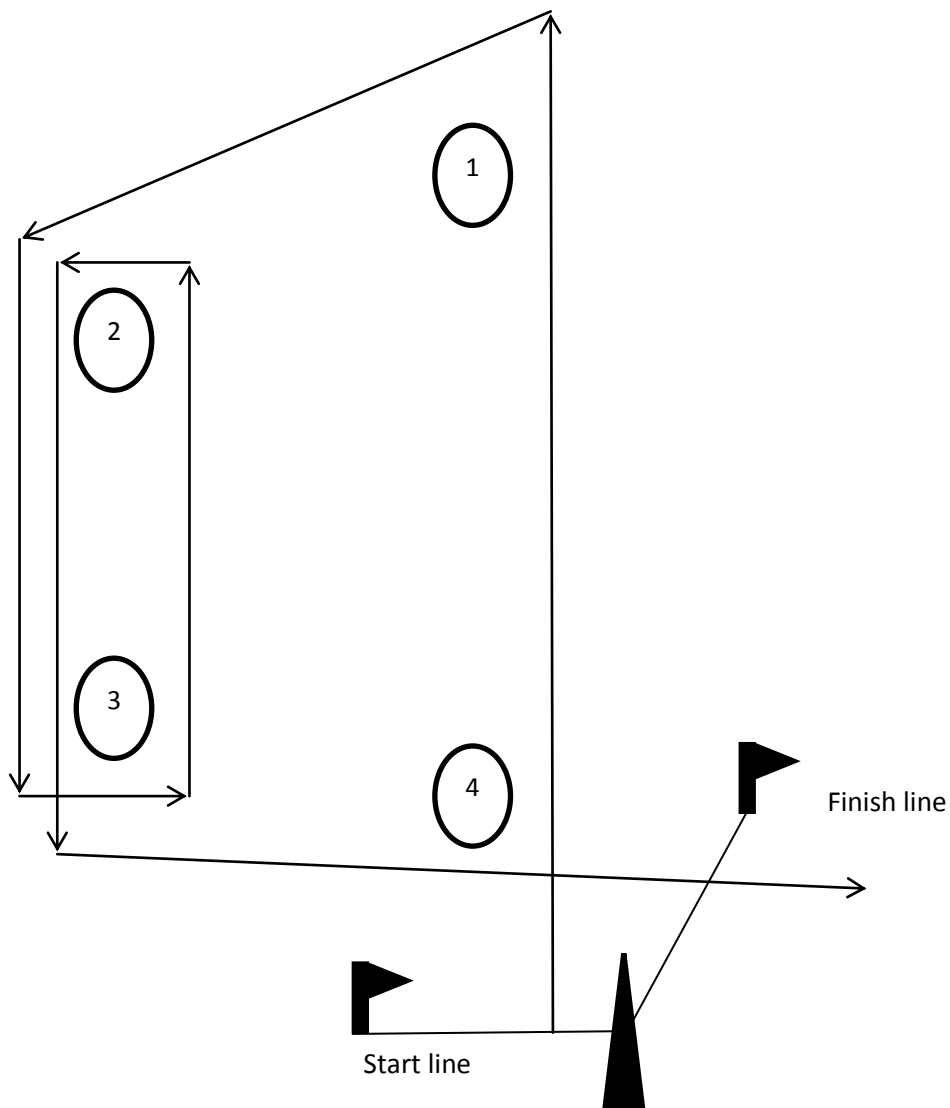

COURSE TWO – INNER LOOP (Course sign I)

ONE LAPS Start- 1, 2, 3, 4, Finish

TWO LAPS Start- 1, 4, 1, 2, 3, 4, Finish

THREE LAPS Start – 1, 4, 1, 4, 1, 2, 3, 4, Finish

Mark 4 shall be left to Port on the final leg to the Finish

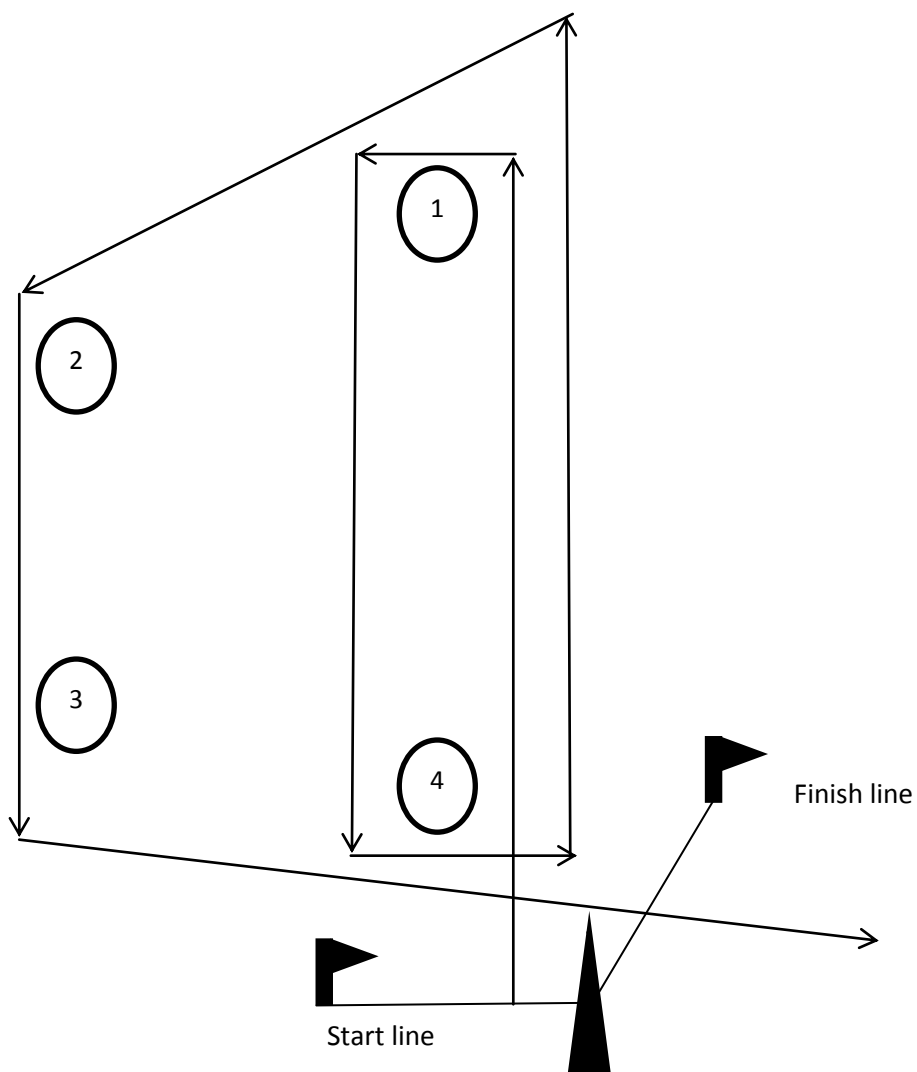

COURSE THREE – WINDWARD – LEEWARD (Course sign L)

ONE LAPS Start- 1, 2, Finish

TWO LAPS Start- 1, 2, 1, 2, Finish

THREE LAPS Start – 1, 2, 1, 2, 1, 2, Finish

Mark 2 shall be left to Port on the final leg to the Finish

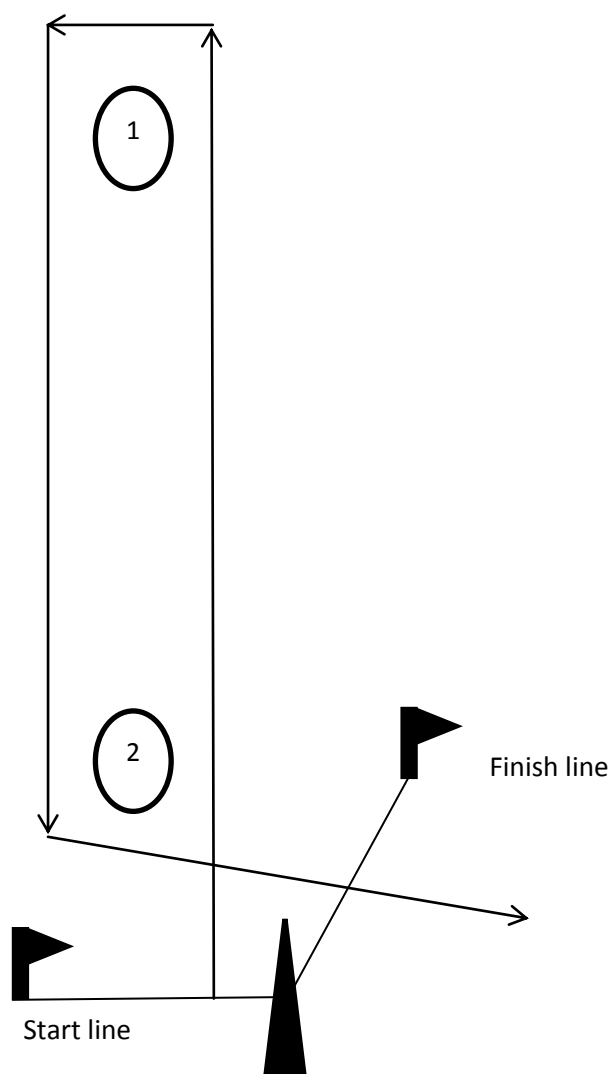

Addendum B: Firefly Bow numbers

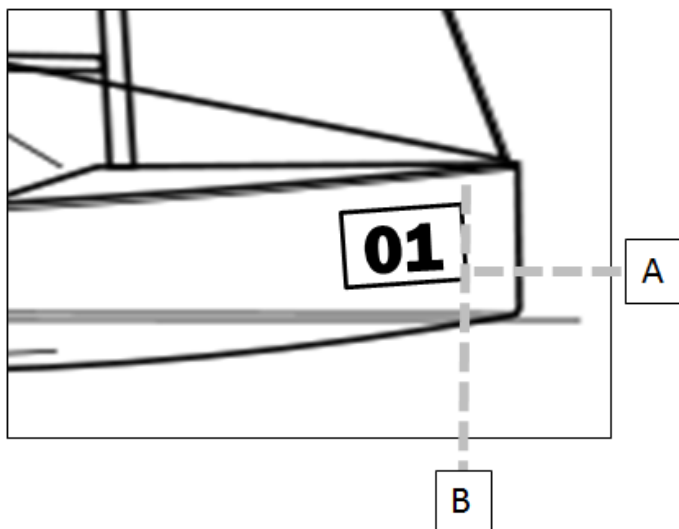

A = 4 inches from the bow

B = 2 inches down from the gunnels

**REMOVE ALL OTHER
BRANDING FROM
THE BOW OF THE
BOAT.**

Repeat on both sides

Addendum C: Sail Stickers for overnight 1st, 2nd, 3rd.

